

ADA-VMUX User Manual

Revision: A

2015-05-08

Contents

1	Revision History	3
2	Product Overview	4
2.1	Summary	4
3	Introduction	5
3.1	ADA-VMUX-C1	6
3.2	ADA-VMUX-C2	6
3.3	The Nevion SDTI audio concept	7
4	Connections	8
5	Configuration	10
5.1	DIP switch configuration	10
5.1.1	AES port Directions	10
6	General environmental requirements	11
A	Materials declaration and recycling information	12
A.1	Materials declaration	12
A.2	Recycling information	12

1 Revision History

Revision	Date	Comments
A	2015-05-09	First revision

2 Product Overview

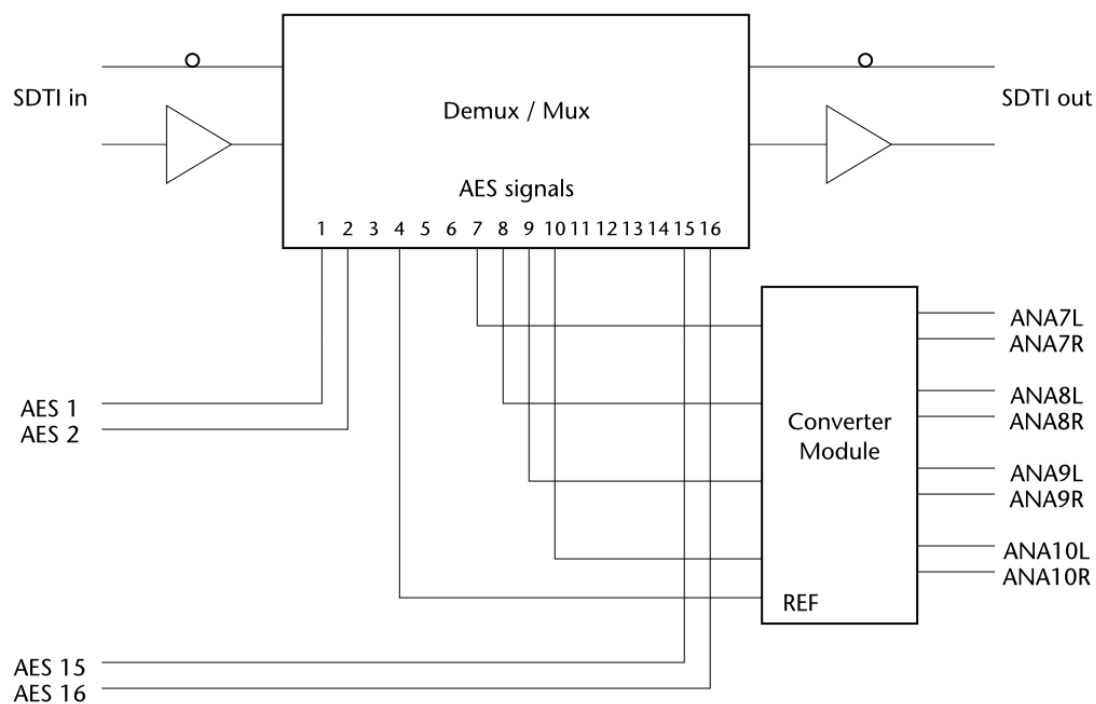

2.1 Summary

- Digital audio multiplexer with digital and analogue audio
- Uses AES-VMUX multiplexer and audio converter modules.
- 8 analogue audio signals and 4 AES signals.
- 3 different audio modules.
- Less cabling on backpanels.
- High density: Single width backplane with two modules (Not original Flashlink frame or N-box).

3 Introduction

The ADA-VMUX is a integrated analog and digital audio de-/multiplexer module in the Flashlink VMUX range. The product is a two card solution onto a single slot backplane for the Flashcase or Flashlink II frame. The two modules used are the AES-VMUX and one of the AES8 audio converter modules.

The AES-VMUX is used to transport a large number of digital audio signals. The module is both a multiplexer and demultiplexer and has AES audio ports which may be used as inputs or outputs. The module forms the core of a highly flexible audio transport and routing concept. Modules may be daisy chained with other VMUX modules to increase the number of AES audio signals in the SDTI signal up to a maximum of 64 AES channels.

Demultiplexing may be performed on any module from any of the audio signals in the SDTI multiplex. Each demultiplex channel is, in effect, a 64 to 1 AES router.

The ADA-VMUX has 4 AES ports available and they may be inputs or outputs. This is dependant on the audio converter module in use due to the ordering of the AES ports See '*Configuration*'.

There are three audio converter modules that may be used giving either A/D conversion , D/A conversion or a combination of both. The audio conversion is broadcast quality with more than 105dBA dynamic range for any conversion.

The ADA-VMUX may also be ordered with optical SFP options.

The demultiplex channels are presented as a router level to the Multicon control system allowing for panel control. Control of a distributed router system can easily be configured in the NeviON Configurator as a single virtual level. Panels may then control a router spanning several VMUX modules.

Signal status can be monitored with the front LEDs, the web interface or with SNMP.

The ADA-VMUX-Cn backplanes use two modules in a compact form factor. A number of cross connections between the modules reduces the cabling and connector requirements of a system. The backplanes may be used with the different audio converter modules giving a range of functionality. The following table shows the audio signals available with each combination.

Modules	Analogue inputs	Analogue outputs	AES inputs	AES outputs
AES-VMUX + ADC-AES8	8	0	4	0
AES-VMUX + ADC-AES8	8	0	2	2
AES-VMUX + DAC-AES8	0	8	0	4
AES-VMUX + DAC-AES8	0	8	2	2
AES-VMUX + ADDA-AES8	4	4	2	2

Two backplane types are presently available:-

3.1 ADA-VMUX-C1

Single width backplane. 4 AES and 8 analogue signals on female d-sub DC-37, DIN 1.0/2.3 SDTI and dual optical connectors.

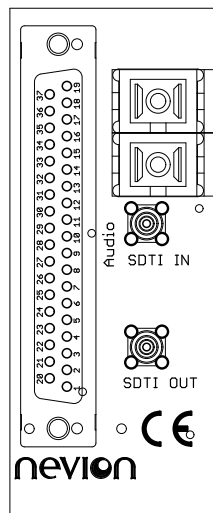

Figure 3.1 ADA-VMUX-C1

3.2 ADA-VMUX-C2

Flashcase single width backplane. 4 AES and 8 analogue signals on Molex Male KK, DIN 1.0/2.3 SDTI and dual optical connectors.

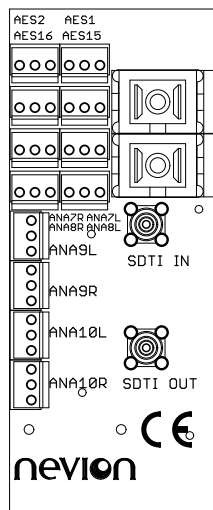

Figure 3.2 ADA-VMUX-C2

3.3 The NeviON SDTI audio concept

The NeviON SDTI audio uses a normal 625 video frame and data format. This allows simple reuse of existing legacy infrastructure and standard test and signal monitoring facilities.

The audio is embedded into the active video area on all video lines. An extra ancillary data packet in the horizontal blanking area identifies the signal as a Flashlink SDTI audio multiplex.

The audio embedding uses two video lines to optimize the number of channels in the multiplex. Seven stereo audio samples, embedded over two lines gives a maximum sample rate of 54.7 kHz. This gives a high multiplexing efficiency of normal 48 kHz broadcast audio. The embedding pattern repeats over a two frame sequence. The phase reference is only inserted on one of the the two lines and a frame counter is also embedded into the horizontal ancillary data packet.

The audio is embedded in fixed timeslots placed along the video line. The phase words are embedded in a block of video words placed first on every other line followed by seven audio blocks. Each block has 64 audio timeslots. Each timeslot contains a 24 bit audio sample together with the C, U and V bits from the AES subframe. The frame of AES audio is split between two audio blocks. The audio multiplex appears on a video monitor as a series of vertical lines or stripes on a video monitor. Dark green stripes are areas where no audio is embedded. Light green shows that the channels are embedded but that the AES input is absent. An active audio channel appears as a multicolored vertical stripe.

The SDI embedded clock is used as a clock reference and the audio is sampled with reference to the start of the horizontal blanking. The phase measurement (similar to HD audio) is embedded on the following line. All of the audio channels use the same reference point and all of the phase measurements are embedded together in a block.

4 Connections

A similar pattern to that used on the TASCAM DB-25 is used for the connections on the DC-37 dsub connector as shown below. The numbering refers to the AES number on the AES-VMUX.

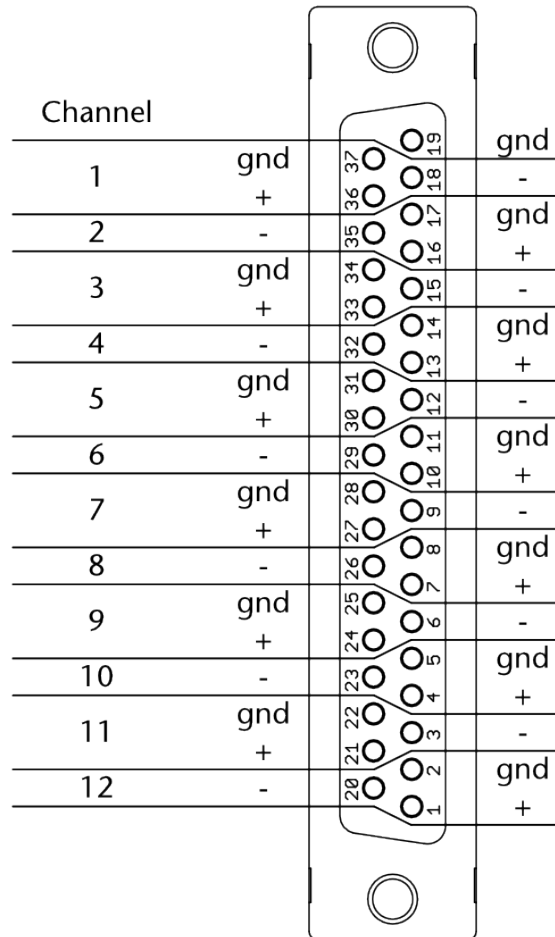
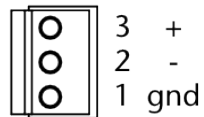

Figure 4.1 dsub DC37 wiring

Table 4.1 DC37 channel assignments with different converter modules

Channel.	ADC-AES8.	DAC-AES8.	ADDA-AES8.
1	AES1	AES1	AES1
2	AES2	AES2	AES2
3	AES15	AES15	AES15
4	AES16	AES16	AES16
5	ADC7 L	DAC7 L	DAC7 L
6	ADC7 R	DAC7 R	DAC7 R
7	ADC8 L	DAC8 L	DAC8 L
8	ADC8 R	DAC8 R	DAC8 R
9	ADC9 L	DAC9 L	ADC9 L
10	ADC9 R	DAC9 R	ADC9 R
11	ADC10 L	DAC10 L	ADC10 L
12	ADC10 R	DAC10 R	ADC10 R

**Figure 4.2** Molex KK wiring

5 Configuration

5.1 DIP switch configuration

DIP switch configuration of the two modules in use will always work as described in the respective user manuals. It is up to the user to set the port directions of the AES-VMUX correctly according to the audio converter module in use. The AES ports on the VMUX, used by the audio converter modules are; AES7, AES8, AES9 and AES10. These signals are connected to the AES1 to AES4 respective connections of the audio converter modules.

5.1.1 AES port Directions

The AES port directions possibilities on the AES-VMUX are limited by two things.

1. The outputs are always placed first.
2. The directions are set in groups of 4.

The combinations which function are shown in table below:

Module	Analogue inputs	Analogue outputs	AES inputs	AES outputs	SW2.1-3
AES-VMUX + ADC-AES8	8	0	4	0	off off off
AES-VMUX + ADC-AES8	8	0	2	2	off off on
AES-VMUX + ADDA-AES8	4	4	2	2	off on off
AES-VMUX + DAC-AES8	0	8	2	2	off on on
AES-VMUX + DAC-AES8	0	8	0	4	on on on

6 General environmental requirements

The equipment will meet the guaranteed performance specification under the following environmental conditions:

Operating room temperature range	0°C to 45°C
Operating relative humidity range	<90% (non-condensing)

The equipment will operate without damage under the following environmental conditions:

Temperature range	10°C to 55°C
Relative humidity range	<90% (non-condensing)

Appendix A Materials declaration and recycling information

A.1 Materials declaration

For product sold into China after 1st March 2007, we comply with the “Administrative Measure on the Control of Pollution by Electronic Information Products”. In the first stage of this legislation, content of six hazardous materials has to be declared. The table below shows the required information.

組成名稱 Part Name	Toxic or hazardous substances and elements					
	鉛 Lead (Pb)	汞 Mercury (Hg)	鎘 Cadmium (Cd)	六价铬 Hexavalent Chromium (Cr(VI))	多溴联苯 Polybrominated biphenyls (PBB)	多溴二苯醚 Polybrominated diphenyl ethers (PBDE)
ADA-VMUX	○	○	○	○	○	○
	○	○	○	○	○	○

O: Indicates that this toxic or hazardous substance contained in all of the homogeneous materials for this part is below the limit requirement in SJ/T11363-2006.

X: Indicates that this toxic or hazardous substance contained in at least one of the homogeneous materials used for this part is above the limit requirement in SJ/T11363-2006.

This is indicated by the product marking:



A.2 Recycling information

Nevion provides assistance to customers and recyclers through our web site: <http://www.nevion.com/>. Please contact Nevion’s Customer Support for assistance with recycling if this site does not show the information you require.

Where it is not possible to return the product to Nevion or its agents for recycling, the following general information may be of assistance:

Before attempting disassembly, ensure the product is completely disconnected from power and

signal connections.

All major parts are marked or labeled to show their material content.

Depending on the date of manufacture, this product may contain lead in solder.

Some circuit boards may contain battery-backed memory devices.